

A guide to home security



Home Office
BUILDING A SAFE, JUST
AND TOLERANT SOCIETY



Make it difficult for the burglar

Reduce the risk of your home being burgled by making sure you've taken these simple (and often inexpensive) precautions.

Most burglaries are carried out by opportunist thieves. In two out of 10 burglaries, they don't even have to use force – they get in through an open door or window. So fit strong locks to your doors and windows and make sure you always keep them fully locked.

If you are replacing or fitting new doors and windows, get ones that are certified to British Standard BS7950 (windows) or PAS 24-1 (doors).

Look at your home through a burglar's eyes.

- How would you get in if you'd forgotten your keys?
If you can get in, so can a burglar.
- Are there places where they could break in without being seen?
- Would they have to make a lot of noise by breaking glass?

Windows



A third of burglars get in through a window

If you are replacing windows, take the opportunity to install new ones that are certified to British Standard BS7950 'Windows of Enhanced Security' and consider using laminated glass, particularly in ground-floor and accessible windows, as this is much harder to break.

Otherwise, window locks that can easily be seen from outside may put some thieves off, because the thief would have to break the glass and risk attracting attention. And even if they do break the window they still can't open it so risk cutting themselves climbing through the broken glass.

Home security and DIY shops sell inexpensive, key-operated locks to fit most kinds of windows. You may need more than one window lock, depending on the size of the opening you need to secure.



Fit window locks with keys to all downstairs windows and windows that are easy to reach – for example, those above a flat roof or near a drainpipe.

Even small windows such as skylights or bathroom fanlights need locks. A thief can get through any gap that is larger than a human head.

Remember to keep windows locked. Remove the keys and keep them out of sight in a safe place.

Louvre windows are especially vulnerable because thieves can easily take the slats out of the frame. Glue the slats into place, and fit a special louvre lock. Better still, replace them with fixed glass.

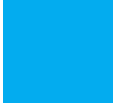

Before fitting locks to PVC-U or metal windows, talk to the installer to make sure this will not affect your warranty

Consider fitting security grilles to vulnerable windows – but only if these windows are not escape routes in case of fire. Many DIY shops now sell decorative wrought-iron grilles.

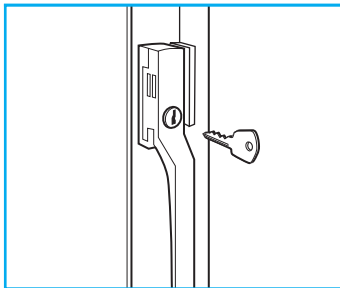

Casement locks make it harder to open windows without the correct key.

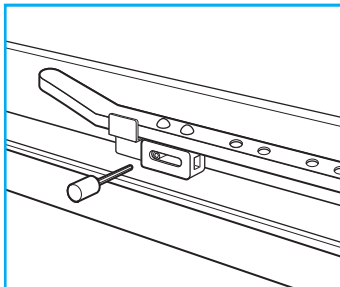

Fanlight locks have a metal bolt to secure the metal arm, which is used to open and close the window. Ideally though, you should not rely on these locks – fit a casement lock too.

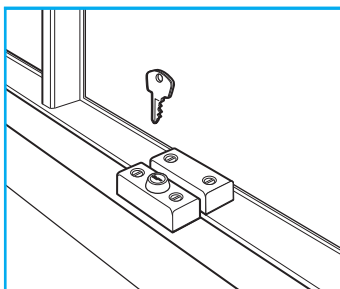

The lock shown here fastens the two windows together. A more discreet version is embedded into the wooden frame. Or there are devices to stop the window opening beyond a certain limit.

Doors



Secure all doors

If your front and back doors are not secure, neither is your home. Two thirds of burglars gain entry through a door.

If you are replacing a door, take the opportunity to improve your security by installing a door that is certified to British Standard PAS 24-1 'Doors of Enhanced Security'.

Ask for it to be fitted with a chain or bar and, if it doesn't have a window or other means of checking who's at the door, a door viewer.

Glass panels on or around doors are especially vulnerable, so replace them with laminated glass. Or, you can buy special film to stick to the inside that will do the same thing.

Make sure the doors and frames are strong and in good condition. Wooden doors should be solid and at least 44mm (1³/₄") thick.

Fit five-lever mortise deadlocks (Kitemarked BS3621) to all outside doors, including French doors. And make sure you use them.

You can make wooden doors stronger by fitting a steel strip and plates to the door frame and around the lock.

Keep your doors locked even when you're at home. Use the mortise deadlock or, on PVC-U or other enhanced security doors, the fully or double-locked mode especially at night.

Fit mortise bolts to the top and bottom of all outside doors, including both sides of French doors.

Remember to fit all security devices with strong screws or bolts.

Before fitting locks to PVC-U or metal doors, check with the installer to make sure that this will not affect your warranty

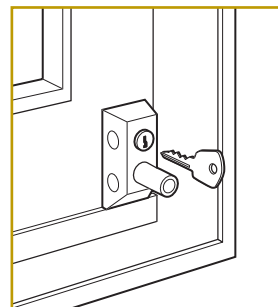



① Door viewer

If you don't have a window in the door or some other way of checking who's calling, fit a door viewer.

Look through this to identify callers before you open the door.

② Hinges

Check that the door hinges are sturdy and secured with strong, long screws. For added security, fit hinge bolts. These are cheap and help to reinforce the hinge side of a door against force. Hinge bolts or security hinges are especially important if your door opens outwards.

③ Letterboxes

Never hang a spare key inside the letterbox. This is an obvious place that a thief will check. Letterboxes should be at least 400mm (16 inches) from any locks. Consider fitting a letterbox cage or other restrictor, which prevents thieves from putting their hands through the letterbox and trying the latches from the inside.

④ Rim latch

Most front doors are fitted with a rim latch, which locks automatically when the door is closed. You can open these from the inside without a key. For strength and quality, look for BS3621 Kitemarked products.

For extra protection, you should consider installing the following.

⑤ Automatic deadlock

This locks automatically when the door is closed and is more secure than other types of rim latch. It needs a key to open it from both the inside and the outside.

⑥ Chains and door viewers

Buy a door bar or chain and door viewer. Use them **every time** someone calls.

Remember, though, that you only use the door chain or bar when answering the door – don't leave it on all the time.

⑦ Mortise deadlock

Fit a five-lever mortise deadlock about a third of the way up the door. Most insurance companies are happy with one Kitemarked to British Standard BS3621.

You can only open a deadlock with a key, so a thief can't smash the nearby glass panel to open the door from the inside. Deadlocks also mean that if burglars get into your home through a window they can't carry your belongings out through the door.

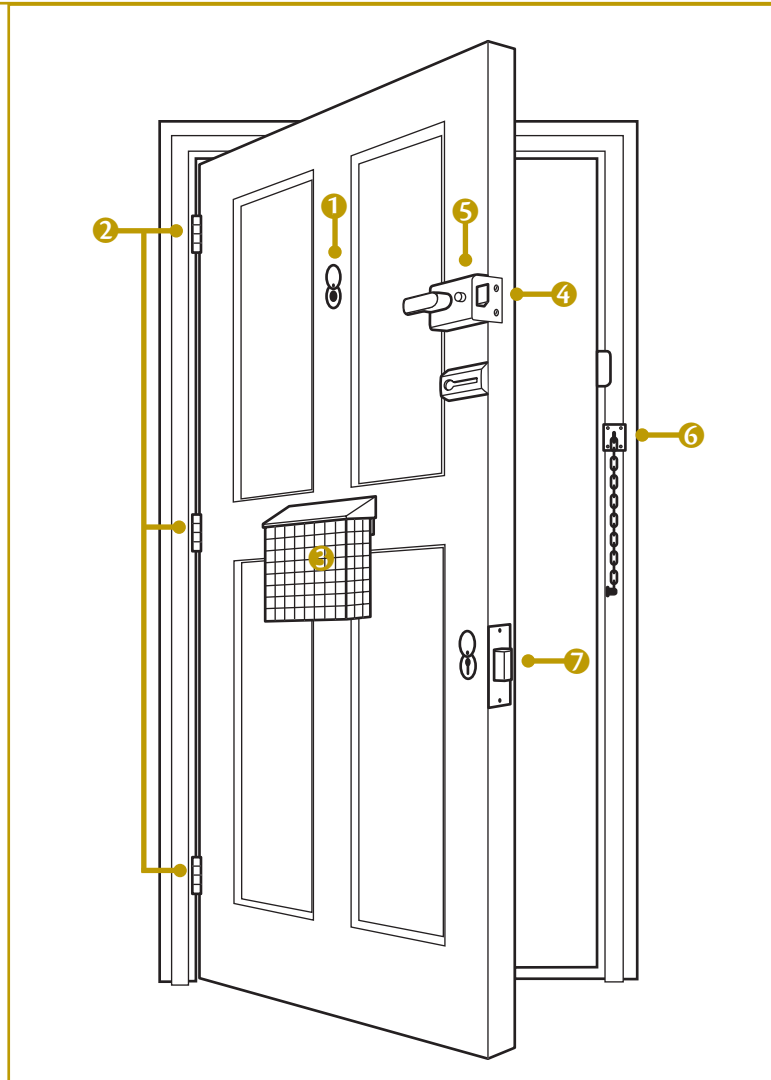

Sliding patio doors should have anti-lift devices and locks fitted to the top and bottom to stop them being removed from outside, unless they already have a multi-locking system. Get specialist advice. If you are getting new or replacement patio doors, ask the system supplier for their high-security specification.



Keys

Never leave a spare key in a convenient hiding place such as under the doormat, in a flowerpot or behind a loose brick – thieves know all the usual hiding places.

If you move into a new home, change the front and back door locks immediately – other people may have keys that fit. Look in your phone book for the names of local locksmiths who are members of the Master Locksmiths' Association.

Never leave your house or car keys in or near a door or window. Some thieves have been known to use a fishing rod or magnet on a stick to steal them through the letterbox.

Decide on a safe place for your keys and always use it, so you can find them in an emergency.

Increasingly, burglars are breaking in to steal the keys of high-value cars. So take care of your keys and, if you have a garage, keep your car in it rather than on the drive.

If you live in a flat

Doors on individual flats are often not as strong as those on houses and can be the easiest way for a thief to break in.

Follow the advice about doors on pages 3 and 4.

Doors to flats over a floor level of 4.5 metres (normally those on the second floor or higher) should have locking mechanisms fitted in line with BS5588 Part 1:1990 'Fire Precautions in the Design and Construction and Use of Buildings'.

Shared entrances

Consider having a phone-entry system fitted to the main door to your building. Never 'buzz' open the door for strangers or hold the door open for someone who is arriving just as you are leaving or entering the building.



Distraction burglary

Some burglars try to trick their way in. They may say they are from the water, gas or electric company or the local council. Or, they may ask for a glass of water, or to wash their hands or claim to have lost a pet. In fact, they'll use any story they can to get in. They can be young (even children) or old, male or female, and might work alone or in teams. They often target the elderly

Remember

- **Lock** – keep your doors and windows locked, even when you're at home.
- **Stop** – are you expecting anyone, do they have an appointment? Make sure the back door is locked – some thieves work in pairs with the other one sneaking in the back while you're at the front door.
- **Chain** – put the door bar or chain on before you open the door.
- **Check** – check their identity carefully. Ask for an ID card. Close the door and check using a phone number from the phone book or a relevant bill, not the one on the card.

If in doubt, keep them out, particularly if you're on your own. Ask them to make an appointment or come back later when someone else is around. Genuine callers won't mind. If you are suspicious, report the incident to the police. You may help prevent them from burgling someone else.

Around the home



Outside lighting

Good lighting can put off or draw attention to a thief.

The most appropriate form of lighting to use is high-efficiency low-energy lighting, controlled by a dusk-to-dawn switch so that it comes on only when it's dark. This provides a constant and uniform level of light. It costs very little to run and helps to create a more reassuring environment.

Lights that come on if they sense movement can be annoying to neighbours and dangerous to passing traffic. If you have these, make sure they are directed downwards.

Fit lights out of easy reach – at a height of at least 2.5 metres (eight feet).

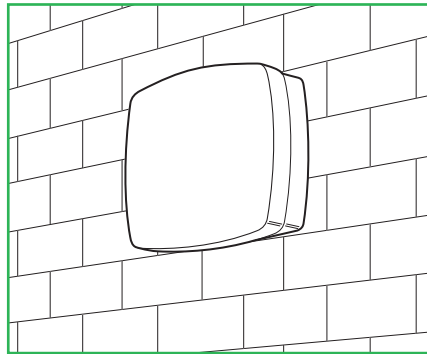

Dusk-to-dawn light

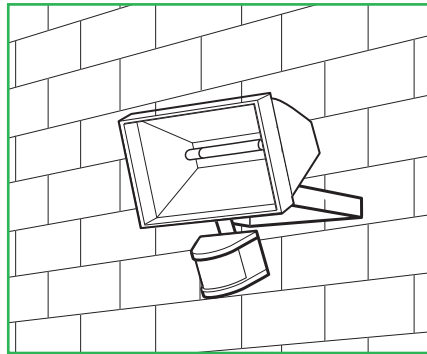

Movement-activated light

Make it look like you are at home when you are out

Remember, most burglaries happen when a house or flat is empty. They are also more likely to happen during the evening or at night.

Don't leave curtains closed during the daytime.

Use time switches to turn on lights, radios and other appliances when you're out. You can buy these from DIY shops. But don't use them if they will show a burglar that you're out, for example, in ground floor rooms where the curtains have been left open. Keep all valuable items out of sight.

If you're going away:

- cancel any milk or newspaper deliveries;
- cut the lawn and so on before you go;
- don't put your home address on luggage labels when travelling to your destination; and
- if you can, get a friend or neighbour to look after your home while you're away. Ask them to collect your post, draw your curtains at night and open them in the mornings, and generally make the place look lived-in. Be prepared to do the same for them.

Small safes, hidden and securely fixed, are ideal for spare chequebooks, credit cards, passports, jewellery and so on.

For more advice see our 'Peace of mind while you're away' leaflet.





Gardens, gates and fences

Prevent intruders getting to the back and sides of your home by installing strong fencing or gates.

Check for weak spots where a thief could get into your garden, for example, a low or sagging fence, or a back gate with a weak lock.

A thorny hedge along the boundary of your property can put thieves off. But make sure that passers-by can still see the front of your home so that a burglar can't work without being seen.

Burglars don't like gravel, it's noisy to walk on.

Don't build pergolas, gazebos and so on too near to the house, they can help thieves reach upper windows.

Solid fences or walls (particularly those with a flat or rounded top) are relatively easy for a burglar to climb over. Fixing trellising to the top can make it more difficult.

Do not use barbed or razor wire, or broken glass – you could be held legally responsible for any injuries caused. You can get safer alternatives that are designed not to cut or injure.

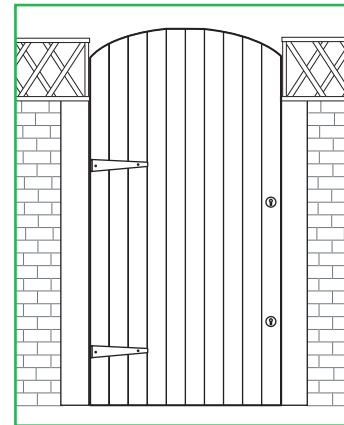

Passageways at the side and back of your home

Fit a strong, lockable, high gate across the passageway to stop a thief getting to the back of your home where they can work without being disturbed. If you share a passageway with a neighbour, ask their permission and for help with the costs.

However, if the passage is a right of way (for example, where it connects two streets rather than just allowing access to the back of a limited number of houses), you would need special permission to fit a gate from your local authority or the courts.

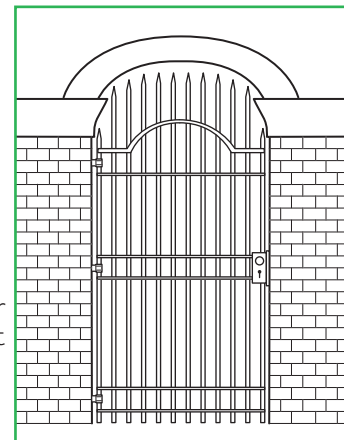



Garages and sheds

Garages and sheds are often full of expensive tools, which are ideal for breaking into the rest of the house.

Never leave a garage or garden shed unlocked, especially if it has a connecting door to the house. A thief could get in and work on the door inside without being seen.

Fit strong padlocks to shed and garage doors, and make sure that the doors are solid enough not to be kicked in.

Lock ladders inside your garage or shed to stop a thief using them to reach upstairs windows. If there is no room in your garage or shed, chain or padlock them horizontally to a sturdy bracket on an outside wall.

Consider having lockable steel boxes fitted to the floor to store your tools in, or anchor posts fitted to the floor to secure larger tools and equipment.

Visibly and permanently mark property you keep in sheds and garages – see page 13 or our 'Coded for keeps' leaflet.

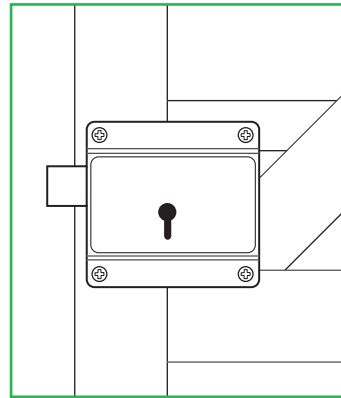



Burglar alarms

Many burglars will avoid breaking into a property with an alarm.

There are many alarm systems on the market. These range from fairly cheap alarms, which you can fit yourself, to more sophisticated systems, costing hundreds of pounds, which need to be installed by professionals. Low-cost alarms are less reliable and can, through false alarms, be a nuisance to both you and your neighbours.

Consider whether you need an audible-only alarm (which sets off a siren or bell) or a monitored alarm (connected to a central 'listening' service). Due to the huge number of false alarms, police will only respond to audible alarms if there is confirmation of suspicious activity – such as a neighbour saying they saw someone or heard glass being broken.

For monitored systems, the monitoring company will check whether any alarm was false – for example, set off by the homeowners entering the wrong access code – and call out the police if necessary. Monitored systems are particularly important for isolated properties.

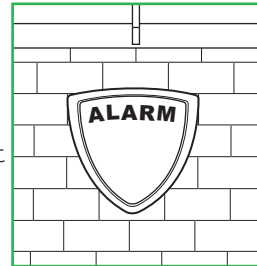

If you are thinking about installing a burglar alarm, you should do the following.

- Ask the crime prevention officer at your local police station for advice before you buy an alarm.
- Get at least three quotes and specialist advice from companies that supply alarms. Use companies registered with either the National Security Inspectorate or Security Systems and Alarm Inspection Board.
- Talk to your insurance company about the alarm companies they recommend before you decide which best suits your needs. The system should meet British Standard BS4737 or BS6799 (wire-free) or the new European Standard EN50131-1.
- Get professional help to install the alarm and to explain how to operate it correctly to make sure that it will work properly.

Remember, an alarm which is not fitted properly can create problems in itself. Don't fit an alarm yourself unless you have the electrical knowledge and practical skills to do so, it could end up costing you more.



Mark your belongings with your postcode

Marking your belongings may put burglars off as it will make the belongings harder to sell, and can help the police investigate crimes and prosecute criminals.

You can replace some items easily, but marking your property can also help the police to return irreplaceable items if they are found.

Items should be visibly and permanently marked showing your postcode and the number of your house or flat or the first two letters of its name.

Only use an ultraviolet marker pen when other methods would reduce the value of the object, because the mark isn't visible and so might not put burglars off or make it more difficult for them to sell the marked item. The marks can also fade.

Take pictures of all valuables like jewellery and silverware and write down the makes, models and serial numbers of your TV, video, DVD, stereo or CD player, home computer, camera equipment and so on. This will help the police identify them if they are stolen.

You may want to consider keeping valuable items, such as jewellery, in a safe.

Ask your local police station for advice on how to get stickers to display in the front and back windows of your home to show that you have marked your belongings.

For more advice on marking your property see our 'Coded for keeps' leaflet.

New belongings

Don't leave empty boxes outside your home – they can give away details of new and valuable equipment, which may be attractive to burglars.

Don't buy crime

Never buy property that you think might be stolen, no matter how tempting the bargain.

- You will be dealing in someone else's misery
- The money you pay is likely to be used to buy drugs.
- It's a crime, punishable by up to 14 years in jail.



Home security



Insurance

Insurance will take away the financial worry of replacing stolen goods.

Many insurance companies offer reduced premiums for people with good home security. But make sure you lock your home up properly and switch on any alarm – if you don't you may not be covered.

Ask your insurance company which security products they recommend.

Fire safety

When you are fitting security devices, you must consider the risk of fire and how you would escape.

Fit at least one smoke detector on every floor of your home. Follow the manufacturer's instructions carefully and check them every month.

Agree a plan with your whole family for getting out in an emergency and make sure you know where your keys are at all times.

Be a good neighbour

If you see anyone acting suspiciously in your neighbourhood, call the police.

Join a Neighbourhood Watch Scheme – there are over 150,000 in this country. Anyone can start up a Neighbourhood Watch Scheme – ask at your local police station for details or look on the internet at www.neighbourhoodwatch.net



More advice on preventing crime

Your local police station will be able to give you helpful advice on preventing crime. Some police forces will check your home or business premises and recommend ways of improving the security. This is a popular service and, if there is a waiting list, they may send you an information pack so you can check your property yourself. You can get useful advice at www.crimereduction.gov.uk and www.homeoffice.gov.uk or the police website www.securedbydesign.com

If you are burgled

Good security will reduce the chance of your home being burgled. But, in case the worst happens, think now about how you would deal with the situation.

If you're in the house and you hear a burglar, how you react will be a personal choice and might depend on the situation – for example, whether you're alone.

You could make a noise and hope it scares the burglar off, or you might prefer to keep quiet and hope the burglar doesn't come into the room you're in.

Many people now have a phone in their bedroom. But even if you do, take your mobile to bed with you. If someone breaks in, you can use it to call the police even if they've disconnected your normal phone.

If you get home and notice signs of a break-in:

- don't go in or shout as the burglar could still be inside;
- go to a neighbour's to call the police – if you think the burglar is still inside, let the police know and
- don't touch anything, you could destroy valuable evidence.



Security checklist

Here's a quick reminder of some of the things you can do to improve the security around your home.

- If you are replacing or fitting new doors and windows, get ones that are certified to British Standard BS7950 (windows) or PAS 24-1 (doors).
- Fit mortise locks (Kitemarked BS3621) to all front and back doors and locks to all downstairs windows or windows which are easy to reach.
- Keep your house and car keys safe and away from doors and windows.
- Fit a burglar alarm, but make sure it is installed properly and works.
- keep your garage and garden shed locked with proper security locks, and keep any tools secure and out of sight;
- trim back any plants or hedges that a burglar could hide behind; and
- make sure you have up-to-date insurance.

When you are away:

- don't leave your curtains closed during the daytime;
- use timer switches to turn on some lights when it gets dark;
- cancel any milk or newspaper deliveries when you go away;
- ask a neighbour to look after your home;

Want to know more about home security?

You can find this leaflet and a range of others on preventing burglary and other crimes at www.crimereduction.gov.uk and www.homeoffice.gov.uk

These include:

- Peace of mind while you are away
- Peace of mind while you move home
- Coded for keeps
- How to beat the bogus caller
- Be safe, be secure – your practical guide to crime prevention.

HSL02. Produced by the Home Office Communication Directorate.
January 2004. Crown copyright.

